

COIL CAR



The Eastall Coil Car is the ideal solution for the safe, simple and efficient movement of steel coils. Coils can be loaded directly onto the Car with an Eastall C-Hook or other loading device, driven towards the uncoiler and height positioned to load over an expanding mandrel such as that on the Eastall Uncoiler. Our 6 and 10 tonne model are standard. We can also manufacture to suit your required tonnage.

Key Features (standard model):

- Compact footprint
- Robust design with quality componentry
- Four pillar guides and central 500mm stroke hydraulic cylinder (can be configured to suit application)
- 3 metre travel rail (can be customized)

Safety Features (standard model):

- Extended wings for extra stability
- Safety rail lock – anti-tipping device

Optional Extras:

- Safety locating pins for narrow coils available to suit your requirements
- Standard dedicated push button controls can be installed as part of an integrated system

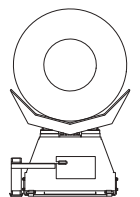
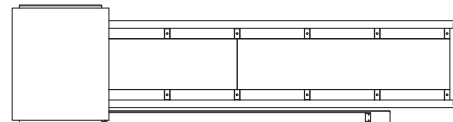

Industries currently using our coil cars:

Steel Industry	Roofing and roll forming Guttering & downpipe manufacturers Sheet slitting and punching stations
Paper Industry	Paper coil handling
Wire Rope Industry	



Eastall Precision Engineering

For a customised quote please enter details below

YOUR DETAILS

Name Company name

PH: E-mail

JOB DETAILS

Coil OD mm Min mm Max Travel Distance m

Coil width mm

MANDREL LOADING

We manufacture to suit the mandrel loading.
Please provide us with the dimension shown.
This is a **CRITICAL** dimension for ensuring safe and easy Coil Car use.

A mm

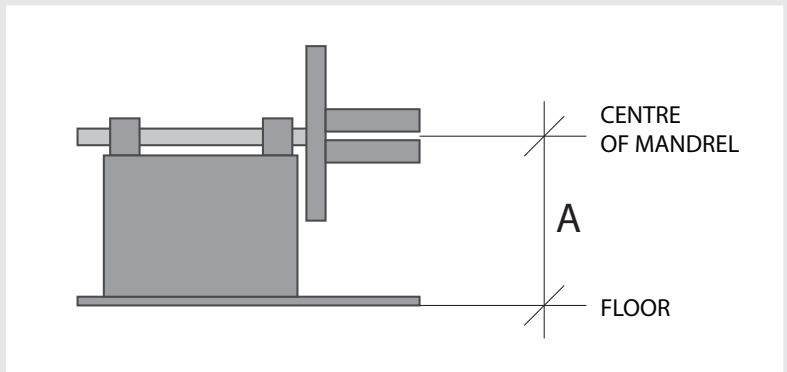

COMMENTS / REQUESTS

Email completed form to: sales@eastall.com.au OR fax (07) 3272 7887